

## Universal drill with manual gears and XY table

### Facts that impress in terms of quality, performance and price

- ▶ Heavy, solid cast design
- ▶ Smooth action due to polished gearwheels running in an oil sump
- ▶ Large XY table
- ▶ Large speed range from 75 - 2,500 rpm thanks to 2 different speeds
- ▶ Two-stage industrial quality electric motor
- ▶ Gear head and table are height adjustable
- ▶ Table guideways can be precisely adjusted through V-ledges
- ▶ Clockwise/Anti-clockwise rotation
- ▶ Gear head pivots through  $\pm 60^\circ$
- ▶ Adjustable wedge rails
- ▶ Drilling depth stop

### Control panel

- Easy to use
- Emergency stop button
- Selector switch for direction of rotation
- Thread tapping function

### Protective screen

- Height-adjustable
- Generously dimensioned
- Microswitch

### XY table

- Solid and generously dimensioned
- Precise surface finish
- Adjustable wedge rails
- Adjustable via 3 hand wheels
- Longitudinal scale inset
- Adjustable limit stops

### Drilling head Height adjustment

### Speed change

- Simple via gear selector switch at front

### Spindle sleeve feed

- Via hand wheel

### Drilling depth stop

- Millimetre scale
- Adjustable

### Cast column

- Thick walls
- For high force absorption and stability

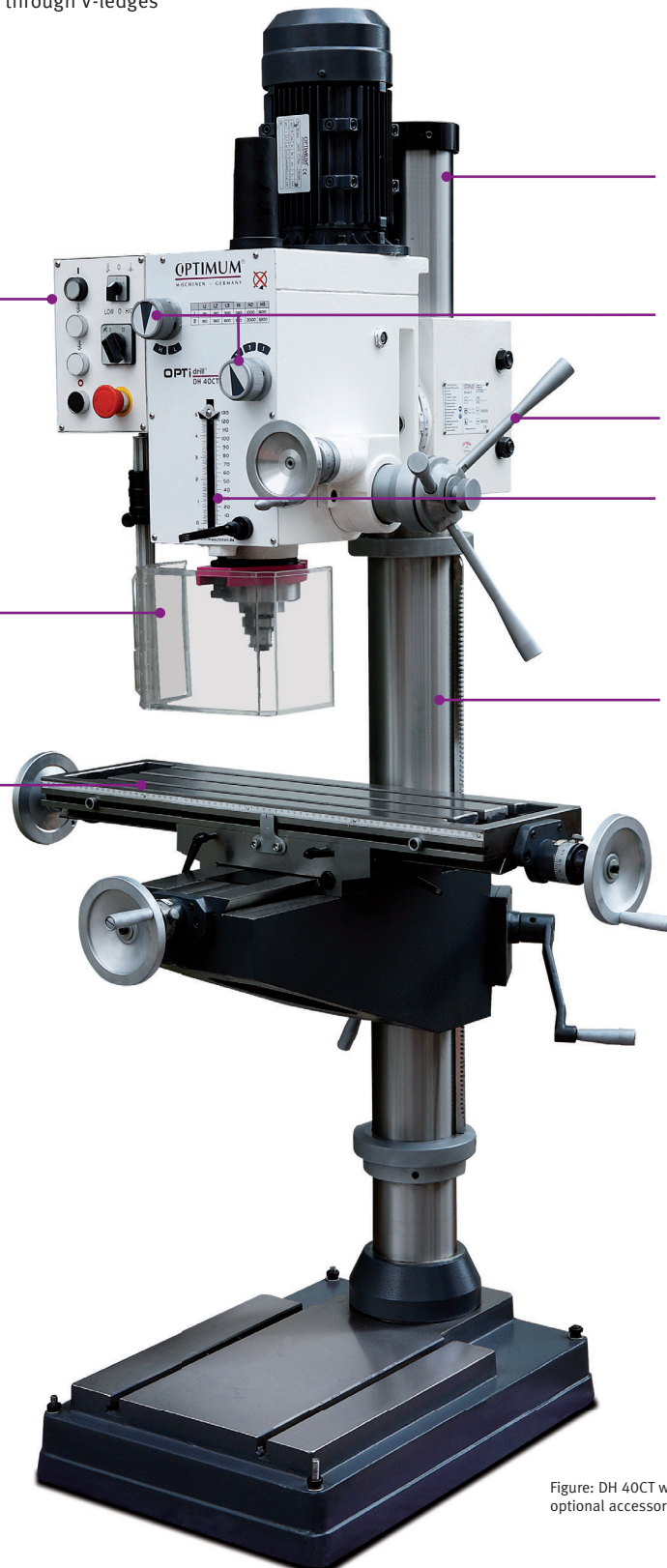

Figure: DH 40CT with optional accessories